

Metal Seated Gate Valve

To BS5163, PN16 – DN80 – DN300

- ✓ Design in accordance to BS 5163 Type B
- ✓ Flange and drilling in accordance to BS EN1092-2, PN16
- ✓ Face to face in accordance to BS EN558-1 series 3
- ✓ Pressure test in accordance to EN12266
- ✓ Use for potable or raw water and neutral liquids to max. 80°C
- ✓ FBE coated inside and outside minimum thickness of 250 µm

Materials List

No.	Name	Material
1	Body Seal Ring	Gunmetal – CC 491K
2	Wedge Seal Ring	Gunmetal – CC 491K
3	Body	Ductile Iron GGG50
4	Wedge	Ductile Iron GGG50
5	Bonnet Bolts	Carbon St Grad 8.8
6	Bonnet Gasket	EPDM
7	Bonnet	Ductile Iron GGG50
8	Stem	Stainless Steel 316 / DIN 1.4401
9	Thrust Collar	Brass, BS EN12165 CW 617
10	O-Ring	EPDM
11	Stem Seal Bush	Brass, BS EN12165 CW 617
12	Gland Flange	Ductile Iron GGG50
13	Dust Cover	NBR
14	Handwheel	Ductile Iron GGG50
15	Handwheel Screw	Stainless Steel
16	Washer	Stainless Steel
17	Gland Flange Bolts	Stainless Steel
18	Washer	Stainless Steel
19	O-Ring	EPDM
20	Wedge Nut	Gunmetal – CC 491K
21	Cap Top Cover	PVC
22	Cap Top Screw	Stainless Steel
23	Cap Top	Ductile Iron GGG50

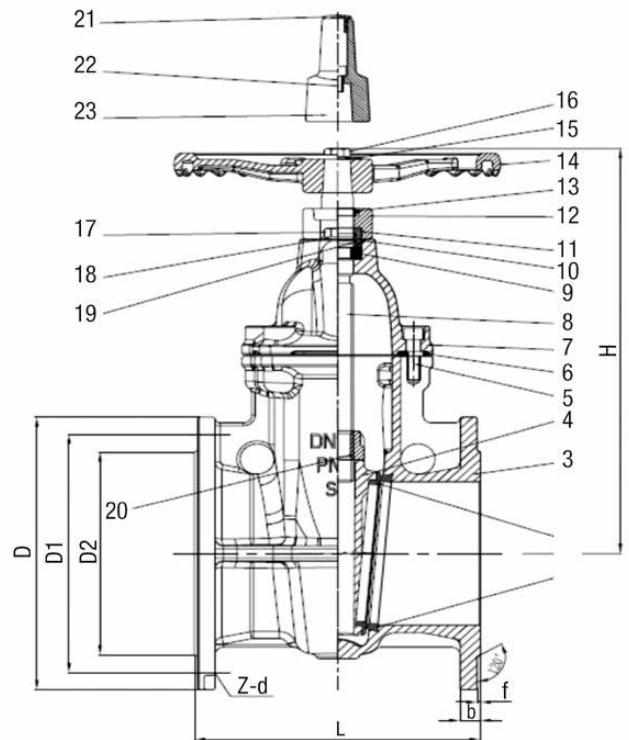

Dimensions Table

DN	PN bar	D	D1	D2	b	f	Z-d	H Handwheel	H Cap
80	16	200	160	138	19	3	8-19	300	375
100		220	180	158	19	3	8-19	335	400
150		285	240	212	19	3	8-23	440	520
200		340	295	268	20	3	12-23	525	590
250		405	255	320	22	3	12-28	630	680
300		460	410	378	24.5	4	12-28	700	762