

BS750 Underground Fire Hydrant

PN16 Temp -20°C to +70°C DN80 & DN100 Fixed Stopper

- ✓ 2 1/2" London Round Thread Outlet
- ✓ Range of outlet options available
- ✓ WRAS Approved Product
- ✓ Flange Standard BS EN1092-2
- ✓ Universal Flange Drilling PN16 / BS10 Table E
- ✓ Max Working Pressure 16 Bar
- ✓ FBE Coated Internally and Externally to a minimum of 250 µm

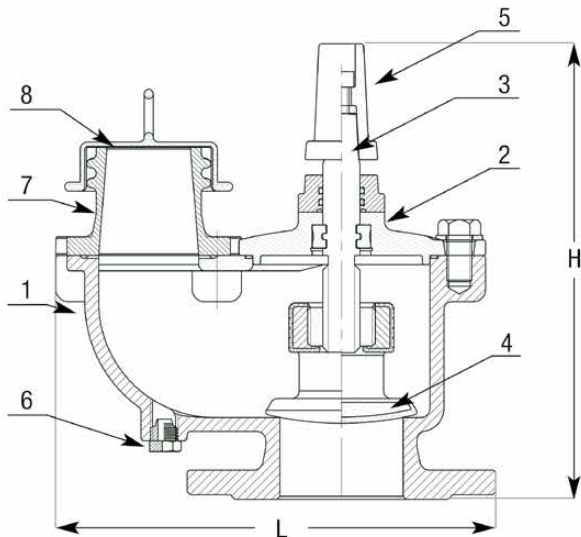

Materials List

No.	Name	Material
1	Body	Ductile Iron GGG50
2	Bonnet	Ductile Iron GGG50
3	Stem	Stainless Steel
4	Stopper	Ductile Iron GGG50 EPDM/NBR Vulcanised with EPDM
5	Cap	Ductile Iron GGG50
6	Auto Frost Valve	Brass with Stainless Steel Spring
7	Outlet	Gun Metal LG2
8	Dust Cover	PVC

Dimensions Table

DN	L	H
80	278	273
100	288	273