

Cascade CK Coupling GRIP / GRIP E

The strong pipe coupling

Cascade CK GRIP/GRIP E axial restraint pipe couplings are used to connect metal pipes. The anchoring ring with conically stamped teeth indents into the pipe surface (steel, stainless steel or cast iron) and provides safe and strong axial restraint. Owing to the special design the coupling can withstand even high vibration loads.

Cascade CK GRIP/GRIP E Features:

1. Double-lip sealing system
2. Standard strip insert
3. Heavy duty lock bars
4. Anchoring ring with conically stamped teeth
5. Temperatures from -30 to +125 degrees C.

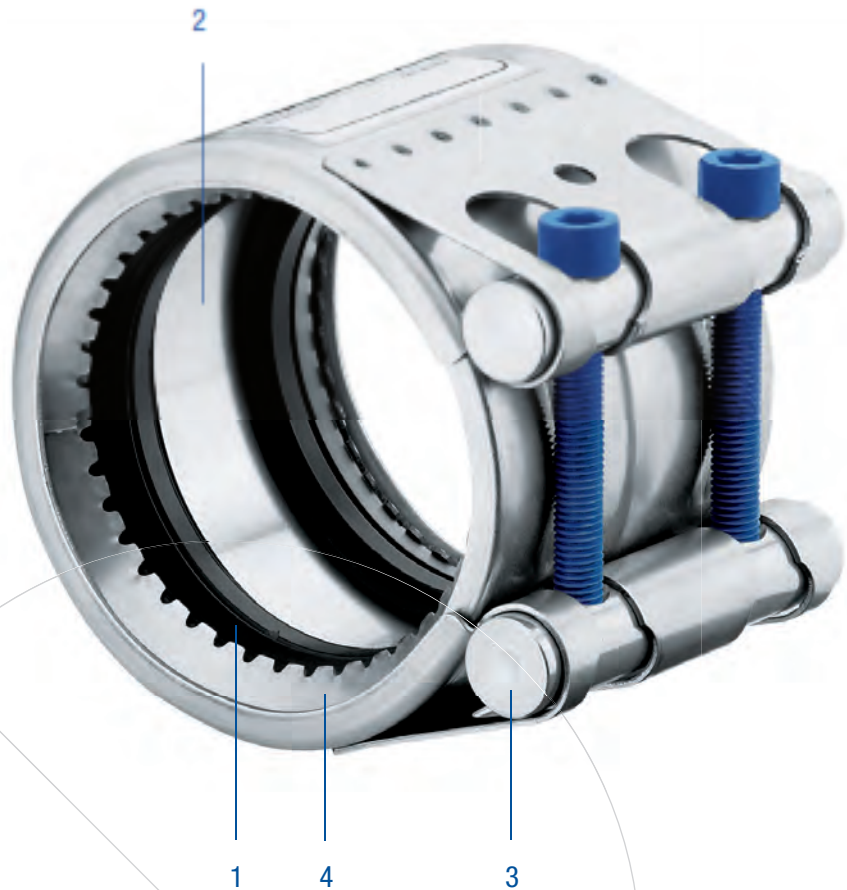
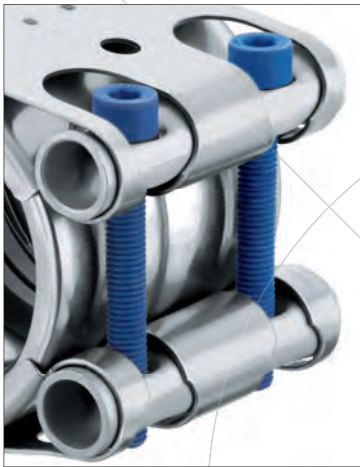

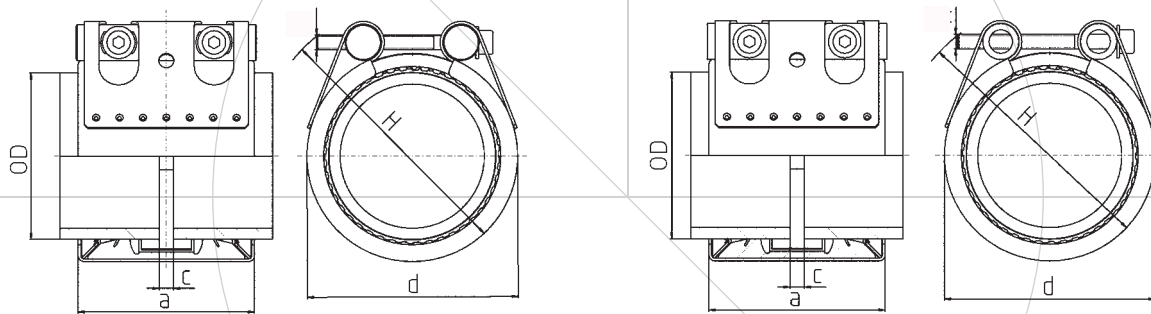

Cascade CK Coupling GRIP / GRIP E



Cascade CK GRIP

Cascade CK GRIP E

OD (mm)	Clamping range ODmin – ODmax (mm)	PN ¹⁾  (bar)	WP ²⁾  (bar)	C _{max} (mm)	Dimensions		
					a (mm)	d clamped approx. (mm)	H approx. (mm)
26.9	26.4 – 27.5	16	70	3	67	50	70
28.0	27.5 – 28.5	16	70	3	67	50	70
30.0	29.5 – 30.6	16	70	3	67	50	70
33.7	33.0 – 34.3	16	60	3	67	55	75
35.0	34.5 – 35.6	16	60	8	63	55	75
38.0	37.5 – 38.6	16	60	8	63	60	80
42.4	41.7 – 43.0	16	50	8	63	65	85
44.5	44.0 – 45.1	16	50	8	63	65	85
48.3	47.6 – 50.5	16	50	8	63	70	90
54.0	53.3 – 54.6	16	50	17	78	75	95
57.0	56.3 – 57.7	16	50	17	78	80	100
60.3	59.5 – 61.0	16	40	17	78	85	105
63.0	62.2 – 63.9	16	40	17	78	85	105
70.0	69.0 – 71.0	16	40	25	98	90	110
73.0	72.1 – 73.8	16	40	25	98	95	115
76.1	75.2 – 77.0	16	35	25	98	100	120
78.0	77.1 – 78.9	16	35	25	98	100	120
80.0	79.0 – 80.8	16	35	25	98	100	120
84.0	83.0 – 85.0	16	35	25	98	105	125
88.9	87.0 – 89.9	16	35	25	98	110	130
101.6	100.4 – 102.8	16	35	25	98	125	145
104.0	102.8 – 106.1	16	35	25	98	125	145
110.0	108.8 – 111.4	16	35	25	98	130	150
114.3	113.0 – 115.5	16	35	25	98	135	155
122.0	120.8 – 123.2	16	32	35	115	145	165
129.0	127.6 – 131.1	16	32	35	115	155	185
133.0	131.5 – 134.4	16	32	35	115	160	190
139.7	138.1 – 141.6	16	32	35	115	165	195
141.3	139.6 – 142.8	16	32	35	115	170	200
154.0	152.3 – 156.1	16	32	35	115	180	210
159.0	157.3 – 160.7	16	32	35	115	185	215
168.3	166.5 – 170.1	16	32	35	115	195	225

¹⁾ **PN** (nominal pressure) is the max. admissible working pressure in shipbuilding, based on a safety factor of ≥ 4 .

²⁾ **WP** is the max. working pressure in industrial applications, based on a safety factor as per specification.

Cascade CK Coupling GRIP / GRIP E

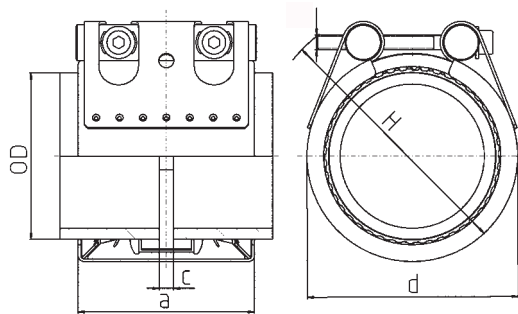

Cascade CK GRIP

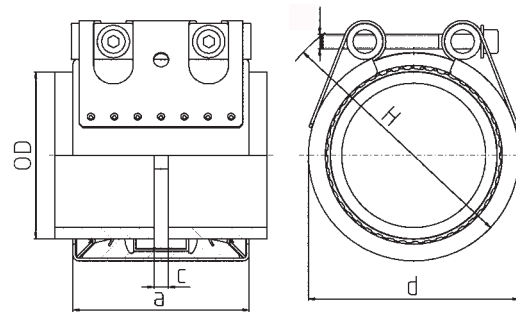

Cascade CK GRIP E

OD (mm)	Clamping range ODmin – ODmax (mm)	MAWP ¹⁾ (bar)		WP ²⁾ (bar)		C _{max} (mm)	Dimensions				
		GRIP	GRIP E	GRIP	GRIP E		a (mm)		d clamped approx. (mm)		H approx. (mm)
193.7	192.0 – 196.0	16.0	10.0	32.0	20.0	35	142	141	225	255	
206.0	202.0 – 208.0	16.0	10.0	32.0	20.0	35	142	141	240	270	
219.1	216.0 – 221.0	16.0	10.0	32.0	20.0	35	142	141	250	280	
225.0	222.0 – 227.0	13.0	10.0	26.5	16.0	35	142	140	255	285	
229.9	228.0 – 232.0	13.0	5.5	26.0	16.0	35	142	140	260	290	
244.5	242.0 – 247.0	12.0	5.5	24.5	15.0	35	142	140	275	305	
254.0	250.0 – 256.0	11.5	5.5	22.5	14.0	35	142	140	285	315	
267.0	264.0 – 269.0	11.0	5.5	22.5	13.5	35	142	140	300	330	
273.0	270.0 – 275.0	11.0	5.5	22.0	13.0	35	142	140	305	335	
306.0	302.0 – 308.0	9.5	5.5	19.5	10.5	35	142	140	340	370	
323.9	320.0 – 327.0	6.5	3.0	13.0	9.5	35	142	140	355	385	
326.0	322.0 – 329.0	6.5	3.0	13.0	9.5	35	142	140	360	390	
355.6	352.0 – 359.0	6.0	2.7	12.0	8.5	35	142	140	390	420	
406.4	402.0 – 410.0	4.5	2.5	9.0	7.0	35	142	140	440	470	
429.0	426.0 – 431.0	4.0	2.5	8.5	6.5	35	142	140	460	490	
442.0	439.0 – 444.0	4.0	2.5	8.0	6.5	35	142	140	475	505	
457.2	454.0 – 459.0	4.0	2.5	8.0	6.0	35	142	140	490	520	
508.0	505.0 – 510.0	2.5	2.0	5.0	4.0	35	142	140	540	570	
531.0	528.0 – 534.0	2.5	1.5	5.0	4.0	35	142	140	565	595	
558.8	556.0 – 562.0	2.0	1.5	4.5	3.5	35	142	140	590	620	
609.6	606.0 – 613.0	1.5	1.0	3.0	2.0	35	142	140	640	670	
634.0	631.0 – 637.0	1.5	---	3.0	---	35	142	---	665	695	
711.2	707.0 – 715.0	1.5	---	2.5	---	35	142	---	745	775	

¹⁾ **MAWP** (maximum allowable working pressure) is the max. admissible working pressure in shipbuilding, based on a safety factor of ≥ 4 .

²⁾ **WP** is the max working pressure in industrial applications, based on a safety factor as per specification. For the pipes to be joined the max. difference in diameter must not exceed 5 mm.